

**BUCK DIMENSIONS**

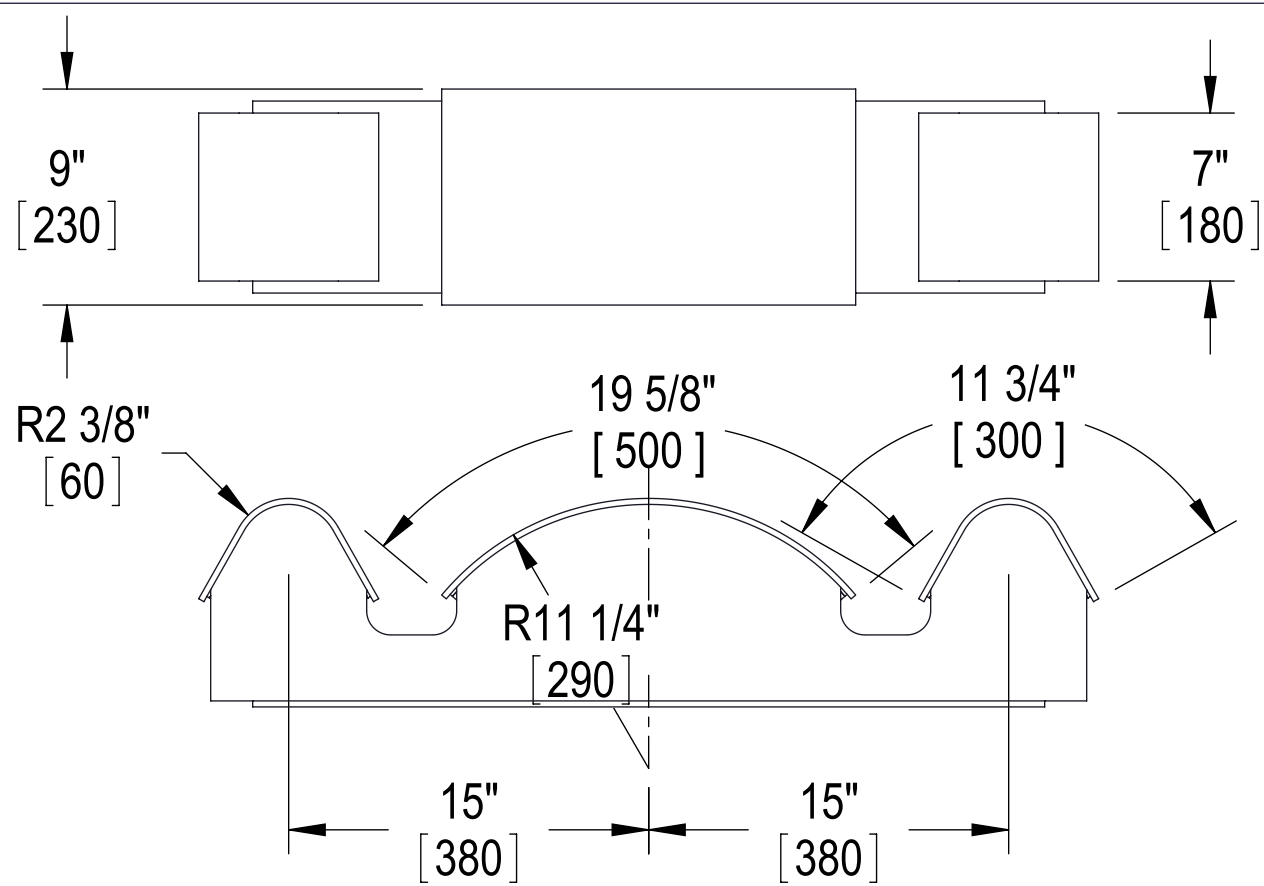

**SUPPLY REQUIREMENTS**

- 1) WEIGHT OF PRESS: 1000 LBS
- 2) AIR SUPPLY: 85 PSI
- 3) STEAM SUPPLY: 100-125 PSI
- 4) ELECTRICAL: 120/230V, 1-PH, 50-60 Hz, 1/2 AMP

**CONSUMPTION**

- 1) AIR: 2 CU. FT. FREE AIR/CYCLE
- 2) STEAM: 3/4 BOILER H.P.

THIS DOCUMENT CONTAINS PROPRIETARY DATA OF UNIPRESS CORP. NO DISCLOSURE, REPRODUCTION OR USE OF ANY PART THEREOF MAY BE MADE EXCEPT BY WRITTEN PERMISSION.



DATE	TOLERANCES UNLESS OTHERWISE SPECIFIED	DRAWN	TAMPA, FLORIDA	
ECO	CASTINGS ±1/16 FABRICATIONS ±.03 MACHINING ±.005	JEH	NAME	
REV	FRACTIONAL 2 PL. DECIMAL ±.005 3 PL. DECIMAL SURFACES 125 BORES 63 BREAK CORNERS .020 ANGLES ± 1/2"	5/20/2009	ROUGHING IN PLAN - Q4T	
		CHECKED	NUMBER	REV
			43392-DC	
		SCALE		
		1:8		